

MPV/R-01



MEDIUM DUTY

Variable and Regulating Pumps
for closed and open loop

Linde Hydraulics move the world

Linde – the pioneer in mobile hydraulics – discovered and developed in perfection hydrostatics as the ideal drive for mobile machinery.

Since 1959 Linde has fitted over 2 million vehicles in the field of

- Construction Machines
- Agricultural and Forestry Machines
- Municipal Vehicles
- Material Handling Vehicles

with hydrostatic drive and gear units. By using this concept on its own forklift trucks, Linde has become the world leader in material handling technology.

MPR-01 MPV-01

<u>CONTENTS</u>	<u>Page</u>
A. VARIABLE PUMPS MPV-01 for closed loop	
1. Characteristics	2
2. Technical Data	3
3. Controls	4
4. Dimensions of PTO's	7
5. Tandem Pumps	8
6. Drive Coupling	9
7. Filtration	10
8. Main Dimensions size 45	11
9. Main Dimensions size 63	13
10. Product Photos	15
B. REGULATING PUMPS MPR-01 for open loop	
1. Characteristics	16
2. Technical Data	17
3. LS DA-control	18
4. Input- and Through-Torques	19
5. Main Dimensions size 28	20
6. Main Dimensions size 45	22
7. Main Dimensions size 71	24
8. Dimensions for LS DA-Control	26
9. Main Dimensions of Tandem Pumps	27
10. Dimensions of PTO's	28
11. Product Photos	29
C. PRESSURE FLUIDS AND FILTRATION	30
D. APPLICATIONS	31
E. LINDE HYDRAULICS DIRECT LINES	33

A. VARIALBE PUMPS MPV-01 for closed loop



MPV 63-01 with M1-control

1. CHARACTERISTICS

- Axial piston pumps, swash plate design
- Compact design
- Optimized for:
 - high reliability
 - high durability
 - low noise emission
 - high efficiency
- Sizes 45 and 63 cm³/rev (single pumps)
- Integral boost pump
- Integrated high pressure relief valves
- Integrated make-up valves
- Integrated L.P. – relief valve
- SAE-2-bolt mounting flange with ANSI splined shaft
- SAE A-, B- and B-B rear flange (PTO)
- Tandem configuration optional

2. TECHNICAL DATA

Pump Size					45	63
max. displacement	main pump		$V_{g \max}$	cm ³ /rev	46	63
	feed pump*)		V_{gH}	cm ³ /rev	8,4	14,9
Nominal pressure	main pump		p_{\max}	bar	300	300
Peak pressure	main pump		p	bar	350	350
Speed	maximum		n_{\max}	rpm	3800	3500
	minimum		n_{\min}	rpm	500	500
Flow at n_{\max}	main pump		$q_{V \max}$	L/min	175	221
Power at n_{\max}	main pump	$\Delta p = 300 \text{ bar}$	P_{\max}	kW	87	110
Torque at $V_{g \max}$	main pump (without feed pump)	$\Delta p = 300 \text{ bar}$	T_{\max}	Nm	219	301
		$\Delta p = 100 \text{ bar}$	T_{\max}	Nm	73	100
Weight (without fluid, without PTO)			m	kg (ca.)	27	39

theoretic values

*) L.P. – relief valve setting 18 bar

Max. Permissible Side- and Axial-Load on Drive Shaft

Pump Size					45	63
Distance of F_q (from shaft collar)		a	mm		17,5	17,5
		b	mm		30	30
		c	mm		42,5	42,5
max. permissible side load at distance	a	$F_{q \max}$	N		3600	5000
	b	$F_{q \max}$	N		2891	4046
	c	$F_{q \max}$	N		2416	3398
max. permissible axial load		$\pm F_{ax \max}$	N		1500	2200

3. CONTROLS

3.1 Electro-Hydraulic Control E1

In relation to the preselected current, control pressure is applied to the positioning cylinder of the pump via two proportional solenoids. The displacement of the pump is thus steplessly variable. One solenoid is relating to one direction of flow.

24 V-Characteristic

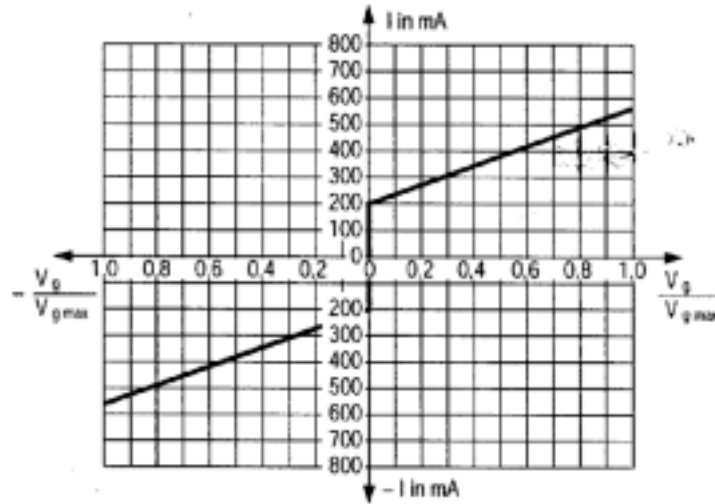

24 V DC

	Size 45	63
Start of control	mA 200	200
End of control	mA 560	560

12 V DC

	Size 45	63
Start of control	mA 400	400
End of control	mA 1115	1115

Schematic

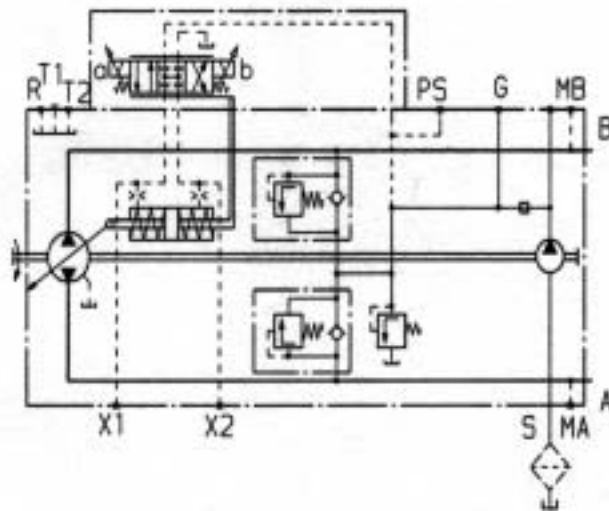

Direction of rotation -Control- Direction of flow

Direction of rotation	clockwise		anti-clockwise	
Solenoid active	a	b	a	b
Control pressure	X ₁	X ₂	X ₁	X ₂
Direction of flow	A to B	B to A	B to A	A to B
Operating pressure	M _B	M _A	M _A	M _B

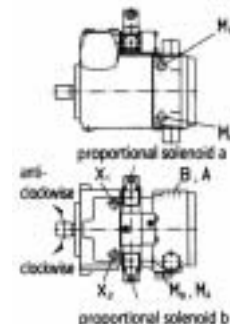

3.2. Hydraulic Remote Control

The positioning cylinder of the pump and therefore the swivel angle is varied in proportion to the difference in pilot pressure applied to the two control ports (Y_1 and Y_2). The pump displacement is therefore steplessly variable. One pilot line is relating to one direction of flow.

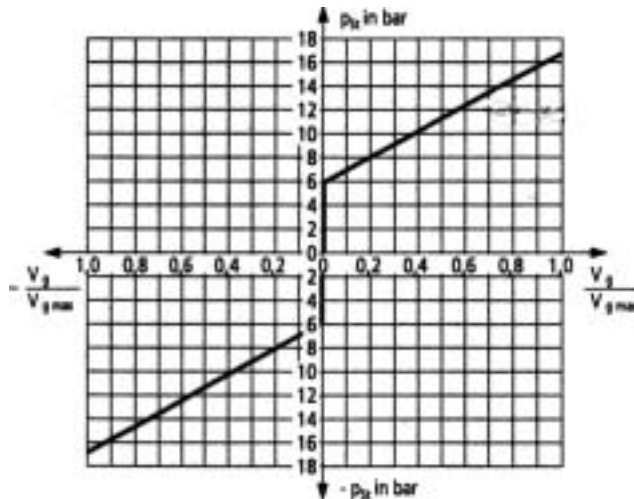

	Size	45	63	
Start of control (V_{go})	p_{st}	bar	6	6
End of control (V_{gmax})	p_{st}	bar	16,7	16,7

p_{st} = pilot pressure at ports Y_1, Y_2

Schematic

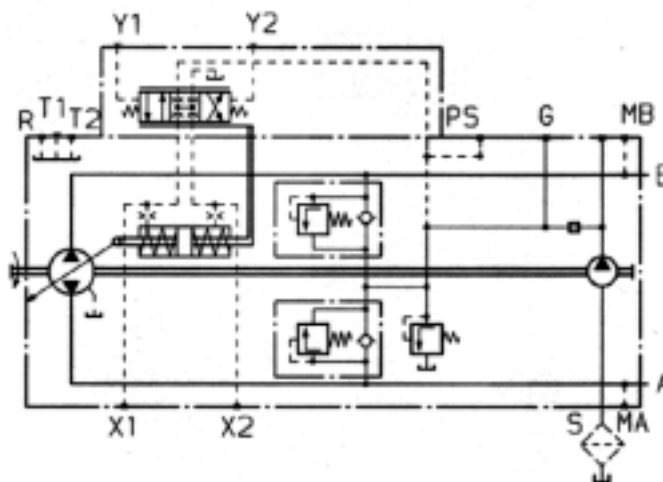

Direction of rotation -Control- Direction of flow

Direction of rotation	clockwise		anti-clockwise	
	Y_1	Y_2	Y_1	Y_2
Pilot pressure	X_1	X_2	X_1	X_2
Direction of flow	A to B	B to A	B to A	A to B
Operating pressure	M_B	M_A	M_A	M_B

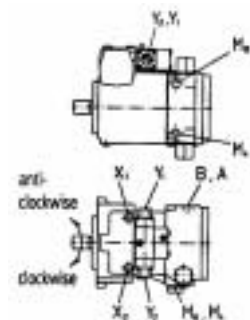

3.3 Mechanical-Hydraulic Control M1

The positioning cylinder of the pump and therefore the swivel angle is varied in proportion to the movement of the control lever. The pump control is steplessly variable. One direction of flow is relating to one direction of lever movement.

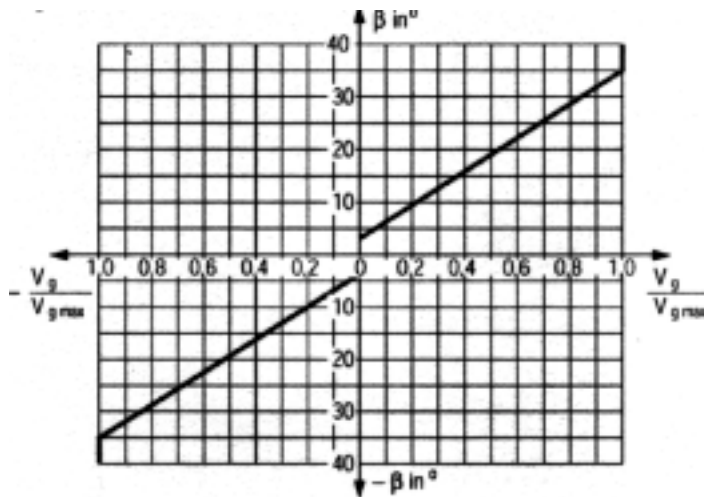

Swivel angle of control lever for swivel from
 0 to $\pm V_g \text{ max}$: _____ $\pm \beta = 0$ to 35°
 mechanical stop _____ at $\pm 40^\circ$

Torque necessary at control lever is between 85 and 210 Ncm

The limitation of the operation range of the HW control lever must be fixed in the external control mechanism (required value setting).

Dependant from the operation conditions of the pump (operation pressure, oil temperature) changes of the curve can occur.

Schematic

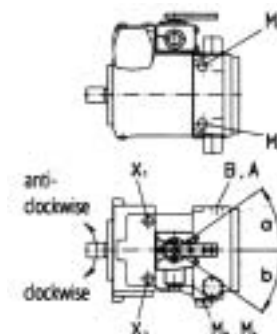
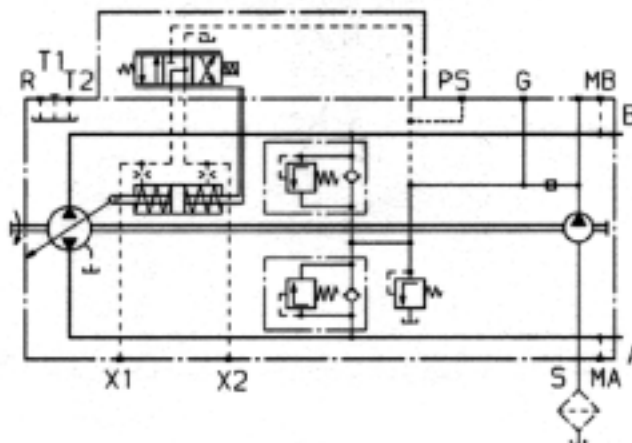

Direction of rotation -Control- Direction of flow

Direction of rotation	clockwise		anti-clockwise	
Lever direction	b	a	b	a
Control pressure	X ₁	X ₂	X ₁	X ₂
Direction of flow	A to B	B to A	B to A	A to B
Operating pressure	M _B	M _A	M _A	M _B

4. DIMENSIONS of PTO's

(all dimensions are given in mm)

SAE A

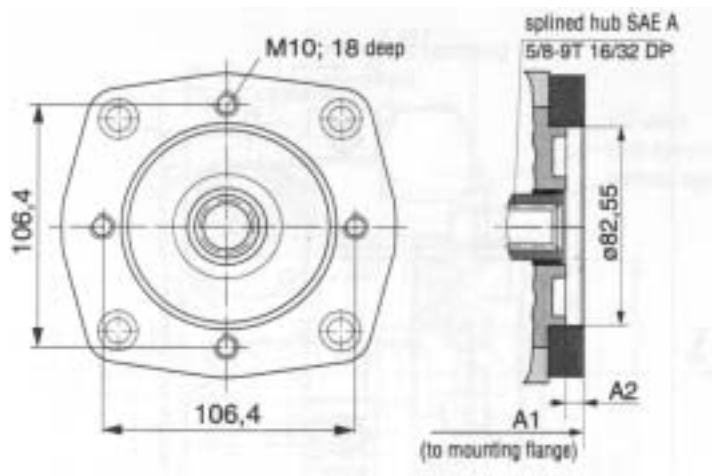

Size	A1	A2
45	234,4	9
63	242,2	9

SAE B

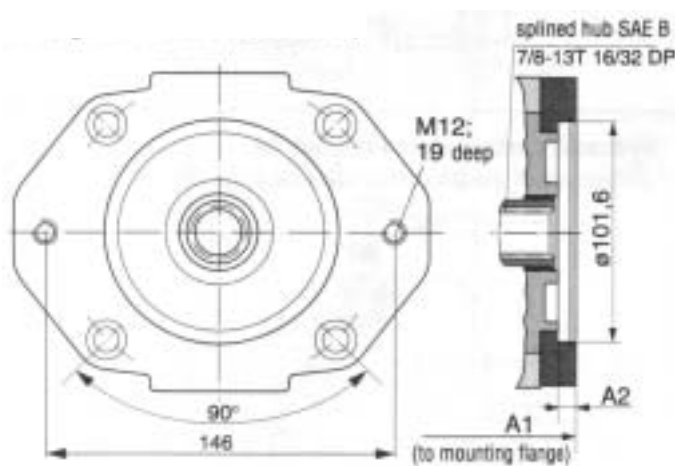

Size	A1	A2
45	235,4	10
63	243,2	10

SAE B-B

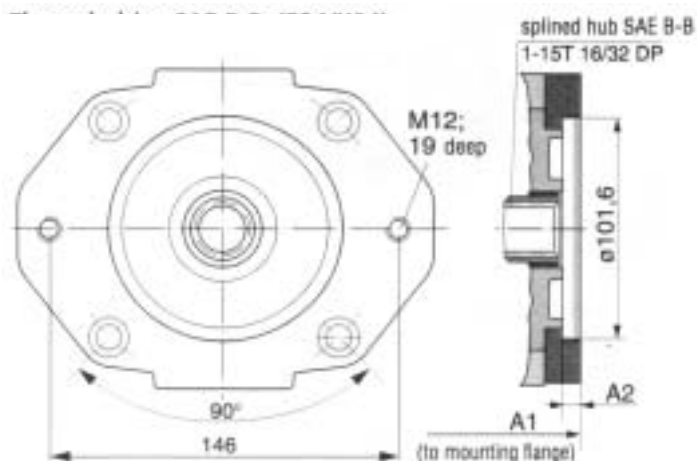

Size	A1	A2
45	235,4	10
63	243,2	10

5. TANDEM PUMPS

Input- and Through-Torques

Pump Size			45	63
Corner torque (at Vgmax Δp=300bar) *	T _{max}	Nm	219	301
max. perm. through-torque	T _{D zul}	Nm	314	439
max. permissible input torque ** at shaft end S SAE (ANSI B92.1a-1976)	T _{E zul}	Nm	314 (1"-15T16/32DP)	602 (1 ¹ / ₄ "-14T12/24DP)
at shaft end T SAE (ANSI B92.1a-1976)	T _{E zul}	Nm	602 (1 ¹ / ₄ "-14T12/24DP)	970 (1 ³ / ₈ "-21T16/32DP)

*) efficiency not taken into account

**) drive shafts without side load

Code explanations

T _{D perm.} = max. permissible through drive torque		in Nm
T _{E perm.} = max. permissible input torque at the drive shaft		in Nm
T ₁ = take off torque at the 1st pump	$= \frac{1,59 \cdot V_{g1} \cdot \Delta p_1}{100 \cdot \eta_{mh}}$	in Nm
T ₂ = take off torque at the 2nd pump	$= \frac{1,59 \cdot V_{g2} \cdot \Delta p_2}{100 \cdot \eta_{mh}}$	in Nm
V _{g1} = pump displacement per rev. 1st pump		in cm ³
V _{g2} = pump displacement per rev. 2nd pump		in cm ³
Δp ₁ = differential pressure 1st pump		in bar
Δp ₂ = differential pressure 2nd pump		in bar
η _{mh} = mechanical-hydraulic efficiency		

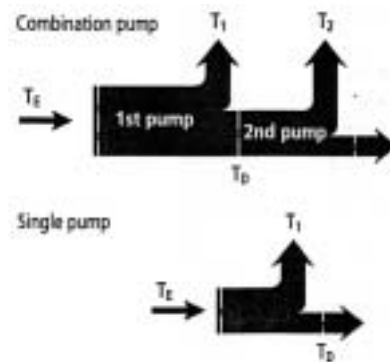

Mounting flange – Shaft ends (of single and tandem pumps)

size	mount. flange	Single pump				2 single pumps of the same size			
		A1	A2	A3	A4	A5 (shaft)	A5 (shaft)	PTO	A5 (shaft)
45	SAE B, 2-hole	146	15	102	15	SAE 1"	SAE 1 ¹ / ₄ "	SAE B-B	SAE 1"
63	SAE C, 2-hole	181	18	127	18	SAE 1 ¹ / ₄ "	SAE 1 ³ / ₈ "	SAE C	SAE 1 ¹ / ₄ "

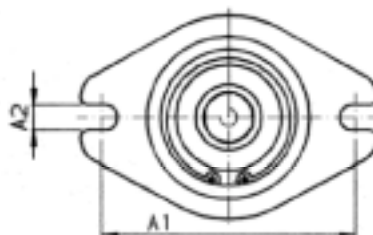
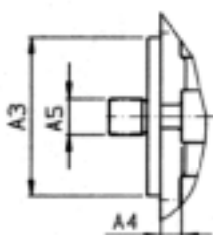

6. DRIVE COUPLING (Installation Details)

To make sure that rotating components (coupling hub) and static components (casing) do not contact each other, the mounting details described below must be observed.

Pump size 45 (with recess): Consider the diameter of the recess

Pump size 63 (without recess): The outer diameter of the coupling hub at its front end must be smaller than the inner diameter of the snap ring.

Pump Size	$\varnothing d_1$	$\varnothing d_{2min}$	$\varnothing d_3$	$\varnothing d_4$	$\varnothing d_5$	x_1	x_2	x_3	x_4
45	40	51,4	$63 \pm 0,1$	101,6	80	$4,3^{+0,2}$	$9,5_{-0,5}$	7	$8^{+0,9}_{-0,6}$
63	40	54,4	$68 \pm 0,1$	127	-	$7,0^{+0,2}$	$12,7_{-0,5}$	-	$8^{+0,9}_{-0,6}$

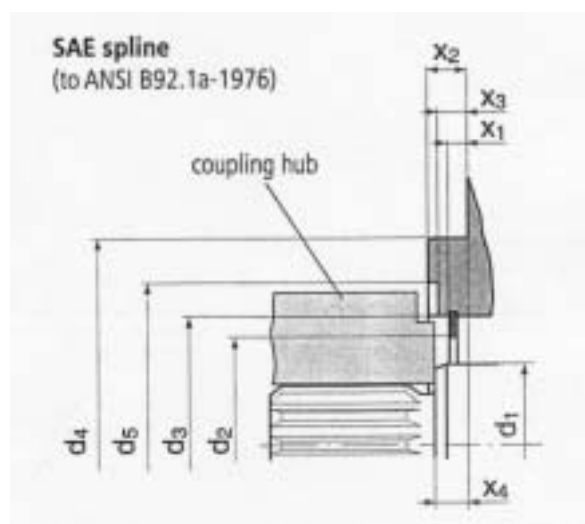

7.FILTRATION

Standard: Filtration in the suction line of the feed pump

Filter type: _____ Filter without bypass

Recommendation: _____ with contamination indicator

Through flow resistance at the filter element:

at $n = 30 \text{ mm}^2/\text{s}$, $n = n_{\text{max}}$ _____ $\Delta p \leq 0,1 \text{ bar}$

at $n = 1000 \text{ mm}^2/\text{s}$, $n = 1000 \text{ rpm}$ _____ $\Delta p \leq 0,3 \text{ bar}$

Pressure at port S of the auxiliary pump:

at $n = 30 \text{ mm}^2/\text{s}$ _____ $p \geq 0,8 \text{ bar}$

at cold start _____ $p \geq 0,5 \text{ bar}$

Variation: Filtration in the pressure line of the feed pump, ports for external boost circuit filter

Filter inlet _____ port Fe

Filter outlet (size 63) _____ port Fa

(size 45) _____ port G(Fa)

Filter type: Filters with bypass are not recommended.

Recommendation: with contamination indicator

Resistance to flow at the filter element:

at $n = 30 \text{ mm}^2/\text{s}$ _____ $\Delta p \leq 1 \text{ bar}$

at cold start _____ $\Delta p_{\text{max}} = 3 \text{ bar}$

**Circuit Diagram
(suction filtration)**

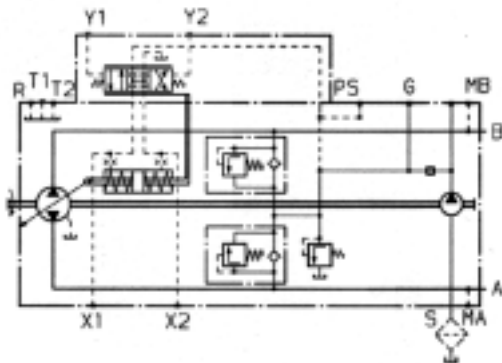

**Circuit Diagram
(pressure filtration)**

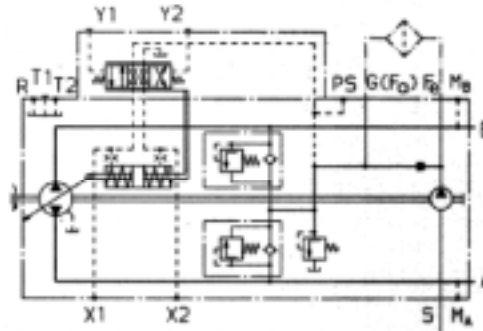

Size 45

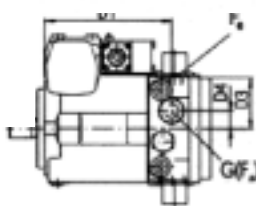

Size 63

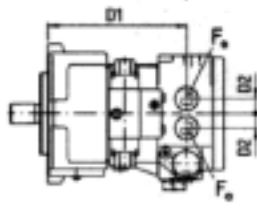
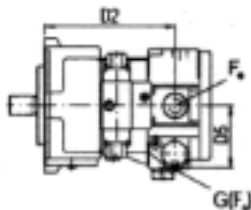
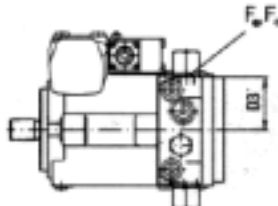

Size	D1	D2	D3	D4	D5	Fe, Fa,G
45	178,6	180,6	71,5	23	83,5	M18x1,5
63	189,8	19,5	82,5	-	-	M18x1,5

8. MAIN DIMENSIONS, Size 45 (without control)

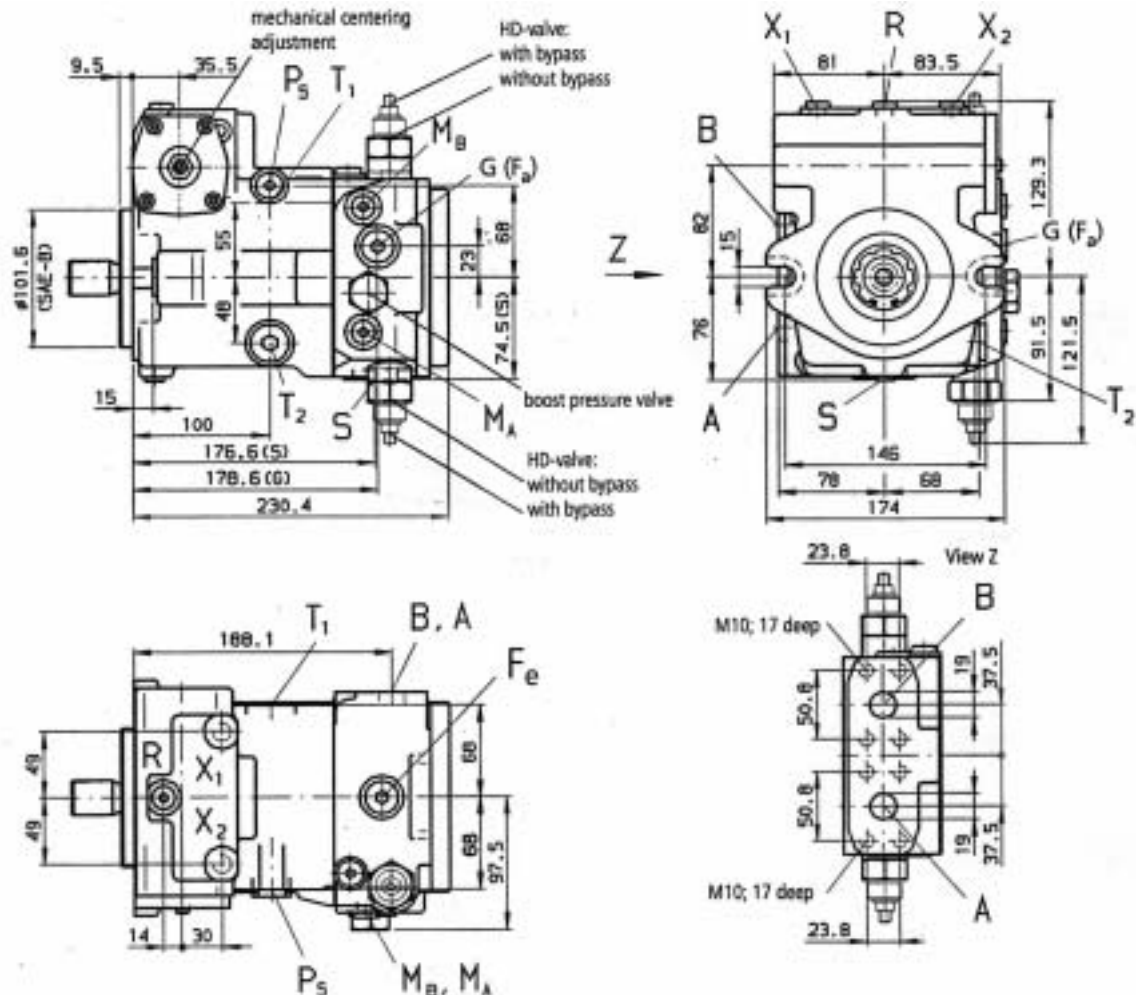

Connections

A, B	Service line ports SAE 3/4" 420 bar (6000 psi) (high pressure series)	
T ₁	Case drain or filling port	M 22x1,5; 14 deep
T ₂	Case drain	M 22x1,5; 14 deep
M _A	Pressure gauge - operating pressure A	M 12x1,5; 12 deep
M _B	Pressure gauge - operating pressure B	M 12x1,5; 12 deep
R	Air bleed	M 12x1,5; 12 deep
S	Boost suction port	M 33x2; 18 deep
X ₁ , X ₂	Control pressure ports (before the orifice)	M 12x1,5; 12 deep
Y ₁ , Y ₂	Remote control ports (only for HD control)	M 14x1,5; 12 deep
P ₅	Control pressure supply, boost pressure	M 14x1,5; 12 deep
G (F _a)	Pressure port for auxiliary circuit	M 18x1,5; 12 deep
F _a	Filter inlet	M 18x1,5; 12 deep

Shaft ends

S
Splined shaft SAE 1" (SAE B-B), pressure angle 30°, 15 tooth, 16/32 pitch, flat root side fit, tolerance class 5 ANSI B92.1a-1976

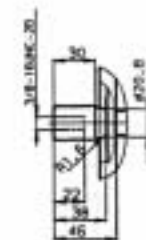

T
Splined shaft SAE 1 1/4" (SAE C) pressure angle 30°, 14 tooth, 12/24 pitch, flat root side fit, tolerance class 5 ANSI B92.1a-1976

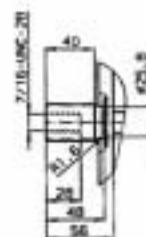

MAIN DIMENSIONS, Size 45 (Controls M1, H1, E1)

Mechanical-hydraulic control, M1

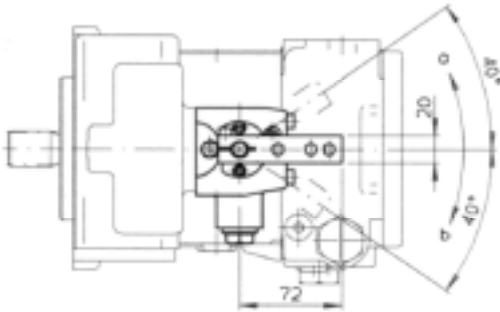
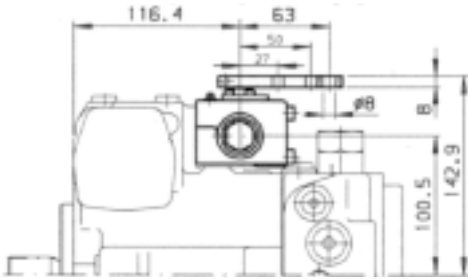

Electro-hydraulic control, E1

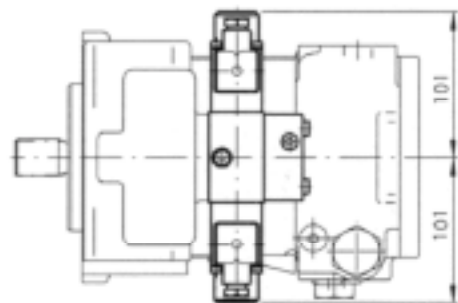
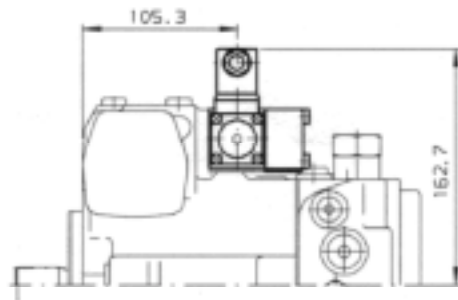

Hydraulic control, H1

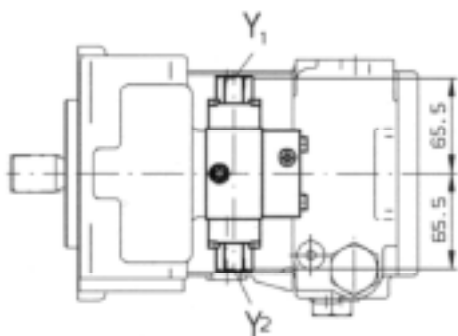
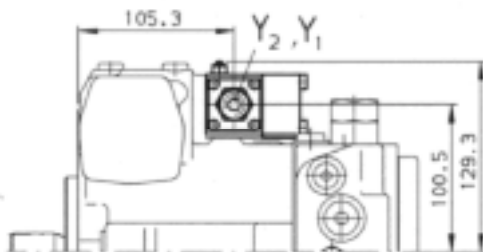

9. MAIN DIMENSIONS, Size 63 (without control)

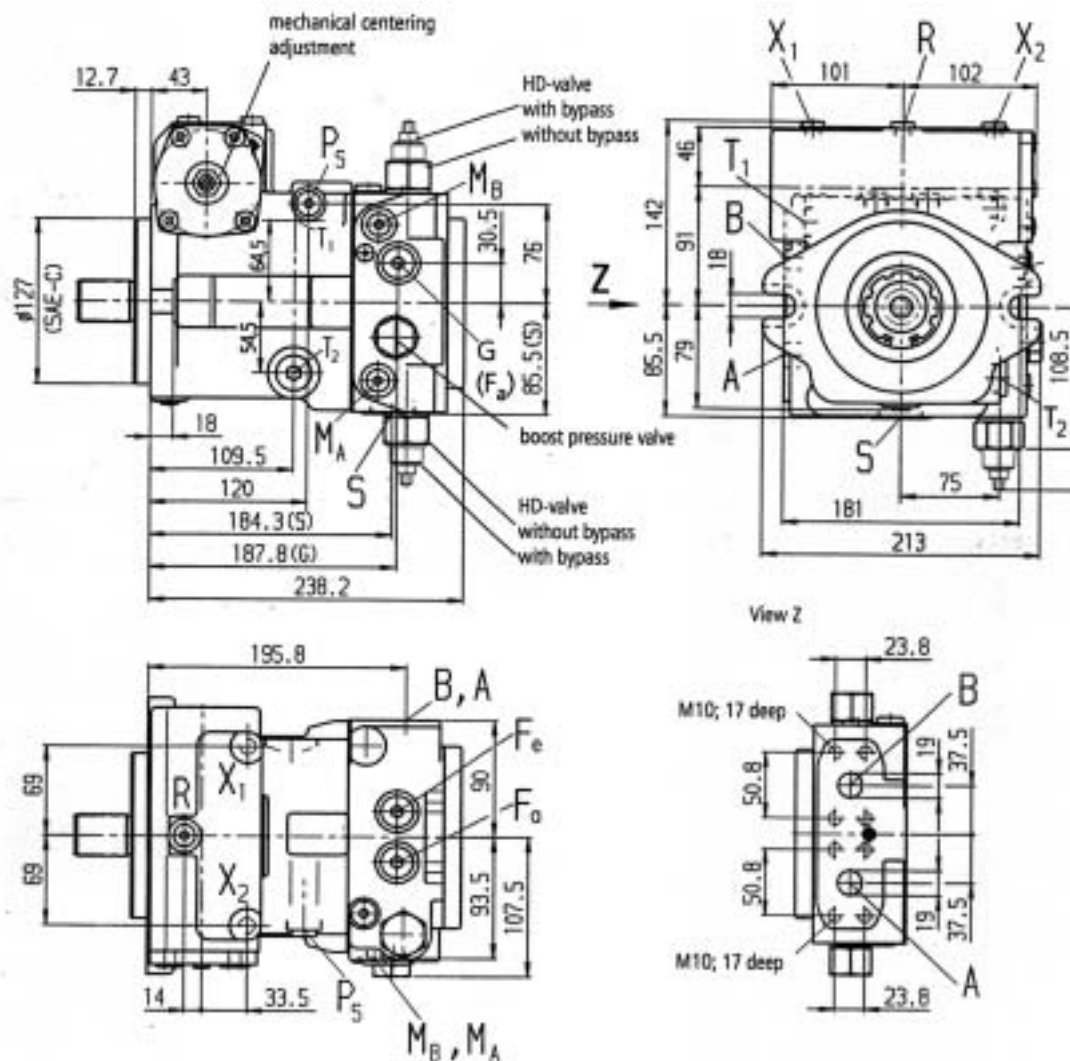

Connections

A, B	Service line ports SAE 3/4" 420 bar (6000 psi) (high pressure series)	
T ₁	Case drain or filling port	M 22x1,5; 15 deep
T ₂	Case drain	M 22x1,5; 15 deep
M _A	Pressure gauge - operating pressure A	M 12x1,5; 12 deep
M _B	Pressure gauge - operating pressure B	M 12x1,5; 12 deep
R	Air bleed	M 12x1,5; 12 deep
S	Boost suction port	M 33x2; 18 deep
X ₁ , X ₂	Control pressure ports (before the orifice)	M 12x1,5; 12 deep
Y ₁ , Y ₂	Remote control ports (only for HD control)	M 14x1,5; 12 deep
P ₅	Control pressure supply, boost pressure	M 14x1,5; 12 deep
G	Pressure port for auxiliary circuit	M 18x1,5; 12 deep
F _a	Filter outlet	M 18x1,5; 12 deep
F _i	Filter inlet	M 18x1,5; 12 deep

Shaft ends

S
Splined shaft SAE 1 1/4" (SAE C), pressure angle 30°, 14 tooth, 12/24 pitch, flat root side fit, tolerance class 5 ANSI B92.1a-1976

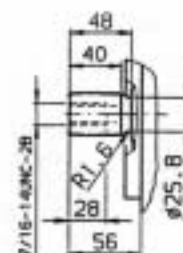

T
Splined shaft SAE 1 1/8" pressure angle 30°, 21 tooth, 16/32 pitch, flat root side fit, tolerance class 5 ANSI B92.1a-1976

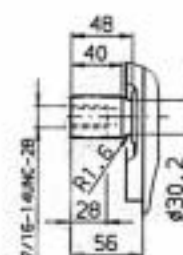

MAIN DIMENSIONS, Size 63 (Controls M1, H1, E1)

Mechanical-hydraulic Control, M1

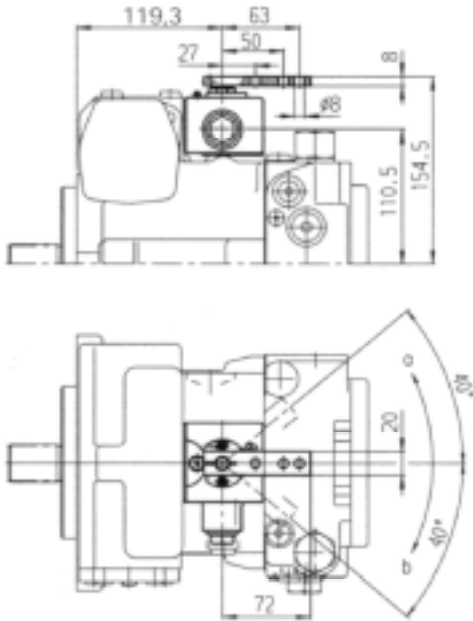

Electro-hydraulic Control, E1

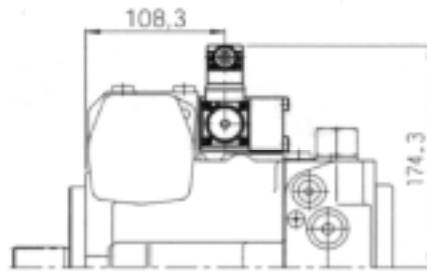

Hydraulic Control, H1

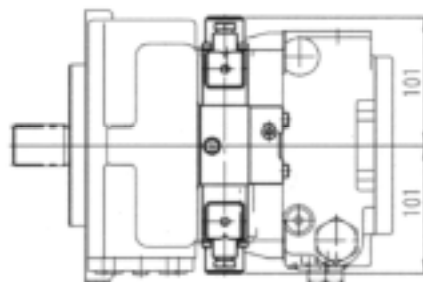
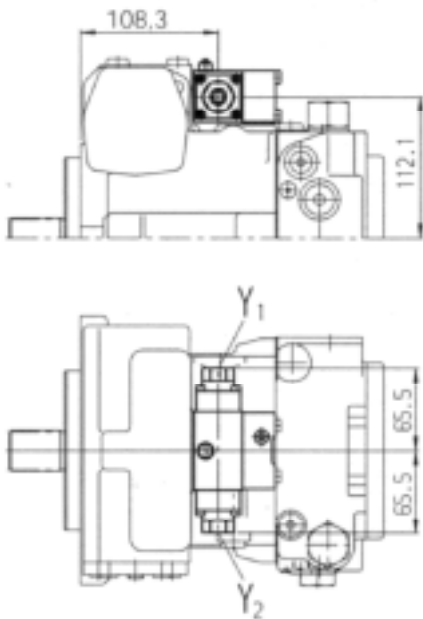

9. PRODUCT PHOTOS MPV-01 (Selection)



MPV 63-01 M1

**Tandem Pump
MPV 63-01 H1 + MPV 63-01 E1
with PTO SAE „B“**



**MPV 63-01 M1
with PTO SAE „A“**

B. REGULATING PUMPS MPR-01 for open loop



MPR 71-01 with axial ports, LS- and PCO - regulators

1. CHARACTERISTICS

- Axial piston pumps, swash plate design
- Sizes 28, 45 and 71 cm³/rev (single pump)
- Compact design
- Optimized for:
 - good self-priming
 - high reliability
 - high durability
 - short response times
 - low noise emission
 - high efficiency
- SAE-2-bolt mounting flange with ANSI splined shaft
- SAE A-, B- and B-B rear flange (PTO) optional
- Axial and radial load on drive shaft possible
- Tandem configuration optional

The Medium Duty Pumps MPR-01 are self-priming pumps which are equipped with a load-sensing-control (LS) and a pressure cut-off (DA). In conjunction with suitable control valves the LS-regulator enables an energy-saving flow-control. By simple methods the LS-regulator can be converted into a constant pressure regulator or a constant flow regulator.

2. TECHNICAL DATA

Pump Size				28	45	71
Displacement		$V_{g \max}$	cm^3/rev	28	45	71
Nominal pressure		p_{\max}	bar	280	280	280
Peak pressure		p	bar	350	350	350
Max. speed *)	at $V_{g \max}$	$n_{o \max}$	rpm	3000	2600	2200
Max. flow	at $n_{o \max}$	$Q_{o \max}$	L/min	84	117	156
	at $n_E = 1500 \text{ rpm}$		L/min	42	68	107
Max. power ($\Delta p = 280 \text{ bar}$)	at $n_{o \max}$	$P_{o \max}$	kW	39	55	73
	at $n_E = 1500 \text{ rpm}$		kW	20	32	50
Max. torque ($\Delta p = 280 \text{ bar}$)	at $V_{g \max}$	T_{\max}	Nm	125	200	316
Torque ($\Delta p = 100 \text{ bar}$)	at $V_{g \max}$	T	Nm	45	72	113
Moment of inertia at drive axis		J	kgm^2	0,0017	0,0033	0,0083
Filling capacity			L	0,7	1	1,6
Weight (without fluid, without PTO)		m	kg (ca.)	15	21	33
Permissible loading of drive shaft:						
Max. axial force		$F_{ax \max}$	N	1000	1500	2400
Max. radial force		$F_{q \max}$	N	1200	1500	1900

*) Values shown are valid for an absolute pressure of 1 bar at suction port S.

If the flow is reduced or if the inlet pressure is increased the speed may be increased according to the diagramm.

Inlet operating pressure range

Absolute pressure at port S (A)

$p_{\text{abs min}}$ 0,8 bar

$p_{\text{abs max}}$ 30 bar

Outlet operating pressure range

Pressure at port B

Nominal pressure p_N 280 bar

Peak pressure p_{\max} 350 bar

(Pressure data to DIN 24312)

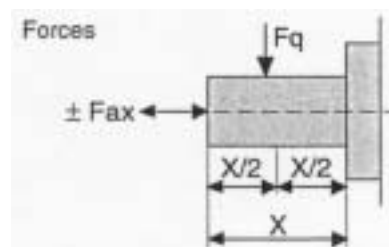

Case drain pressure

Maximum pressure of leakage fluid (at ports L, L₁): maximum 0,5 bar higher than input pressure at port S, but not exceeding 2 bar absolute.

Determination of inlet pressure p_{abs} at suction port S, or reduction in flow for increasing speed.

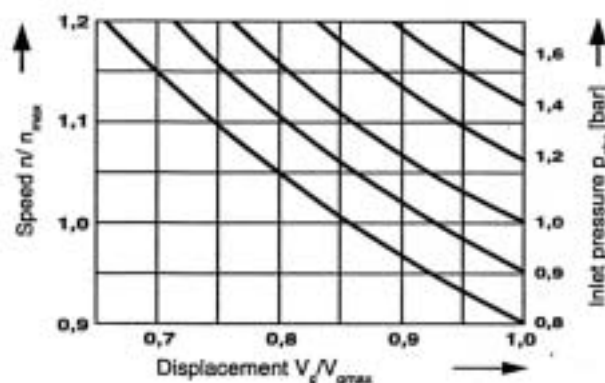

3. PRESSURE/FLOW CONTROL LS DA

Static characteristic
(at $n_1 = 1500 \text{ rpm}$; $t_{oil} = 50^\circ\text{C}$)

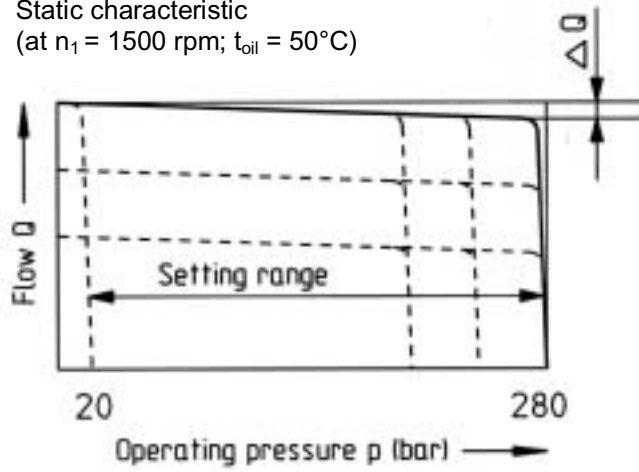

Schematic

not included
in supply

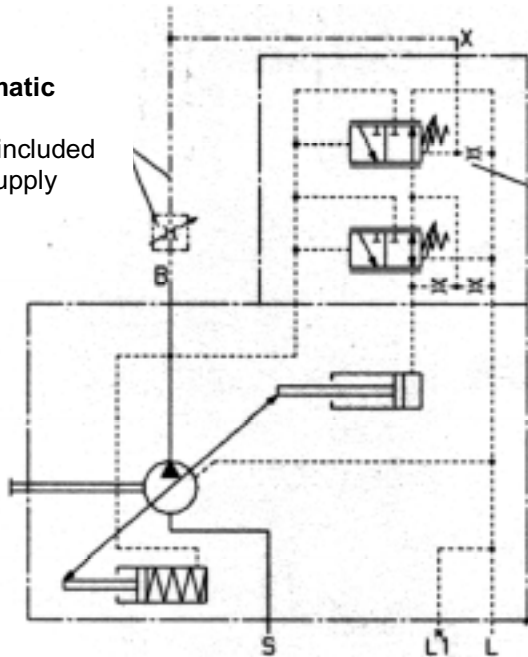

Ports

- B Pressure Port
- S Suction port
- L, L1 Case drain ports (L1 sealed)

Flow control/differential pressure Δp :

Adjustable between 10 and 22 bar (higher values on request) Standard setting: 20 bar. If a different setting is required, please state in clear text.

When port X is unloaded to tank, a zero stroke pressure of $p = 18 \pm 2 \text{ bar}$ ("stand by") results.

Response times

Size	Settling time t_a	Settling time t_e
	t_a (ms) stand by-250 bar	t_e (ms) 250 bar-stand by
28	40	20
45	50	25
71	60	30

4. INPUT- and THROUGH-TORQUES

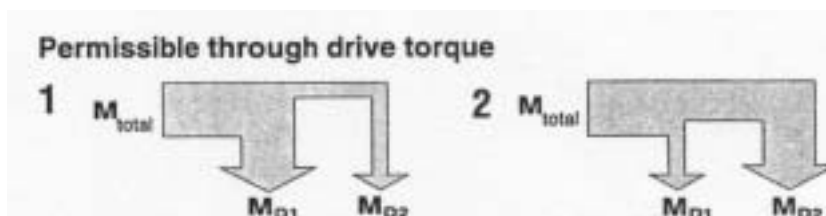

Size			28	45	71
Max. perm. total inlet torque at shaft pump 1					
(Pump 1 + Pump 2)	$M_{Ges\ max}$	Nm	180	300	500
1 Perm. thru. drive torque	$M_{D1\ max}$	Nm	125	200	316
	$M_{D2\ max}$	Nm	55	100	184
2 Perm. thru. drive torque	$M_{D1\ max}$	Nm	55	100	184
	$M_{D2\ max}$	Nm	125	200	316

Tandem Pumps

By tandemising single pumps hydraulic circuits independent from each other are achieved.

When ordering, please, exactly specify both pump versions.

PTO

The regulating pumps MPR-01 can be supplied with PTO.

Please, exactly specify the PTO-version when ordering.

5. MAIN DIMENSIONS, Size 28

Rear Ports, without PTO,
without control

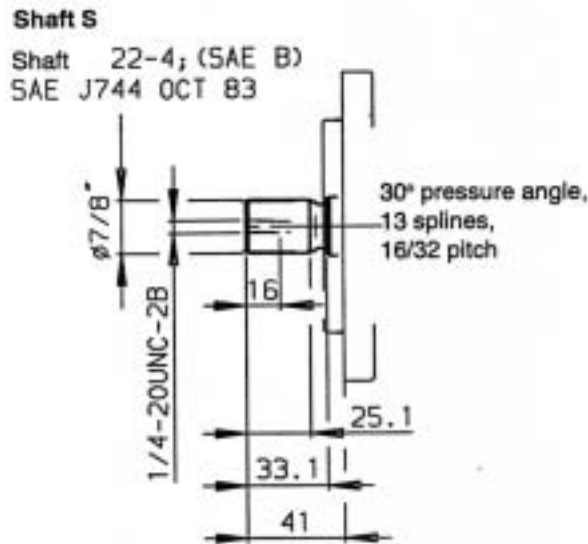
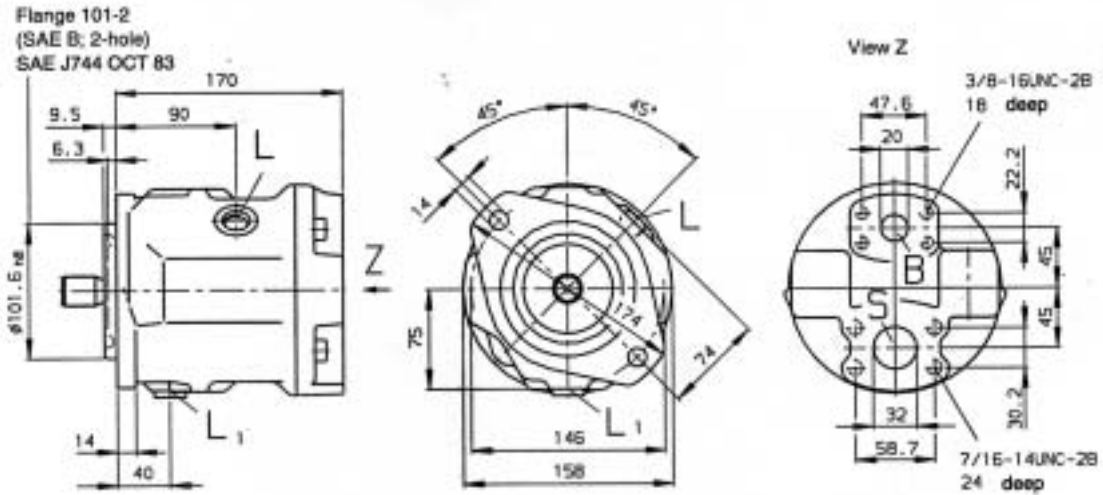

Ports

B	Pressure port	SAE 3/4"	(standard pressure series)
S	Suction port	SAE 1 1/4"	(standard pressure series)
L	Case drain port	3/4-16 UNF-2B	
L ₁	Case drain port	3/4-16 UNF-2B	(sealed in factory)

MAIN DIMENSIONS, Size 28

Side Ports, without PTO

L: case drain port 3/4-16 UNF-2B

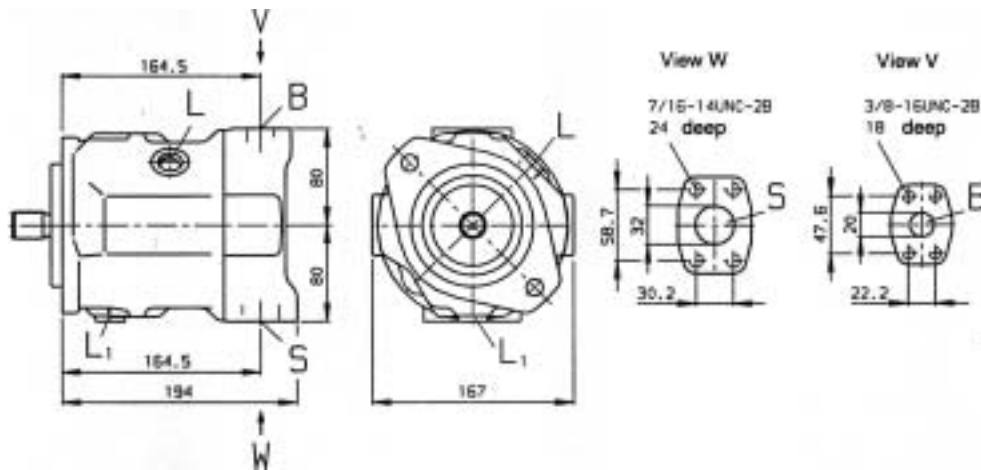

Rear Ports, without PTO

L: case drain port M18x1,5

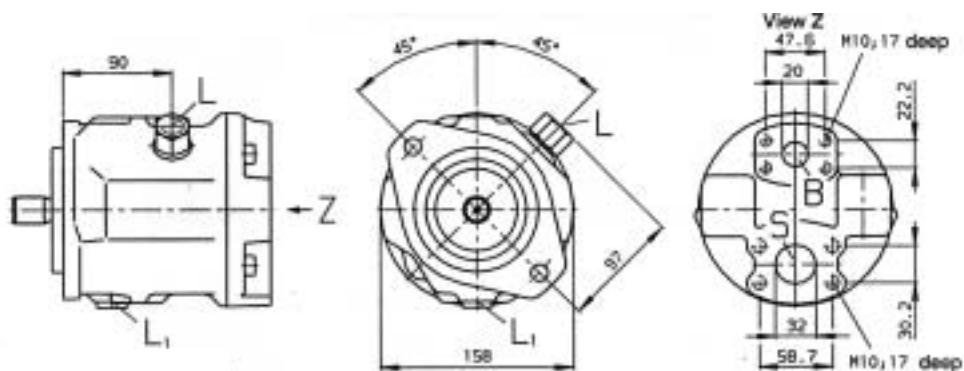

Side Ports, without PTO

L: case drain port M18x1,5

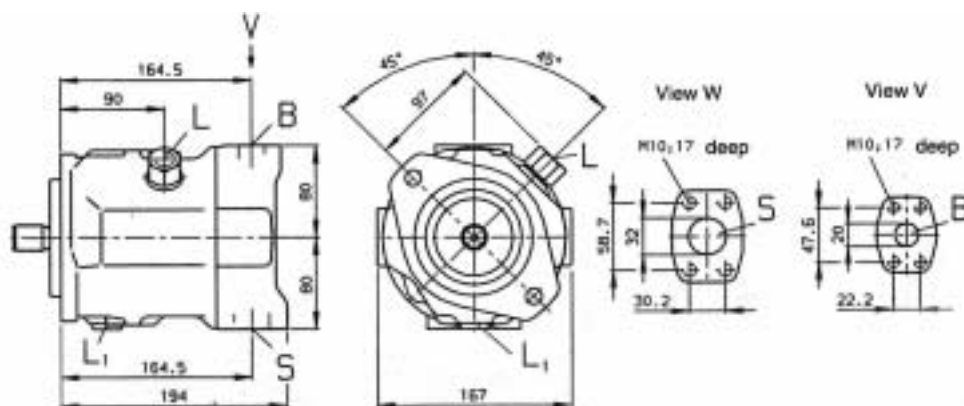

6. MAIN DIMENSIONS, Size 45

Rear Ports, without PTO,
without control

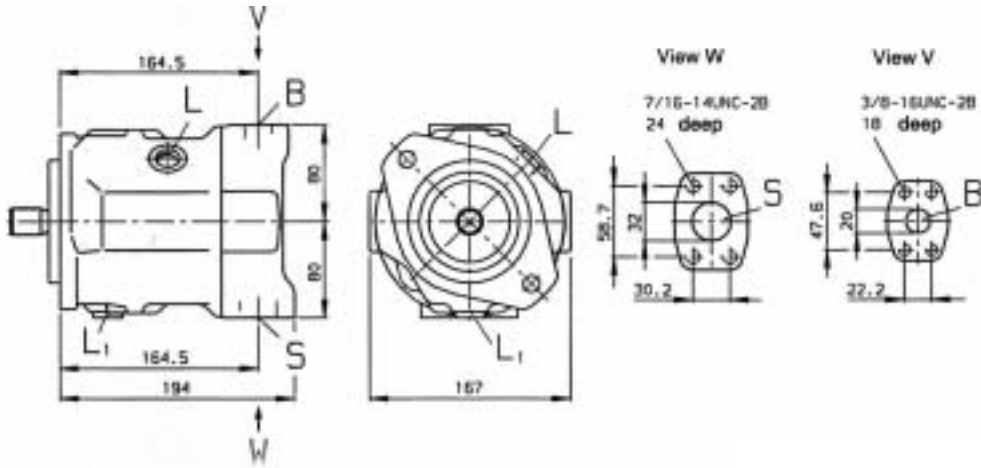

Shaft S

Shaft 25-4; (SAE B-B)
SAE J744 OCT 83

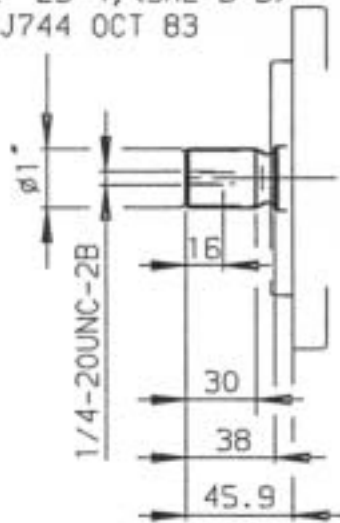

30° pressure angle,
15 splines,
16/32 pitch

Ports

B	Pressure port	SAE1"	(standard pressure series)
S	suction port	SAE 1 1/2"	(standard pressure series)
L	case drain port	7/8-14 UNF-2B	
L1	case drain port	7/8-14 UNF-2B	(sealed in factory)

MAIN DIMENSIONS, Size 45

Side Ports, without PTO,

L: case drain port 7/8-14 UNF-2B

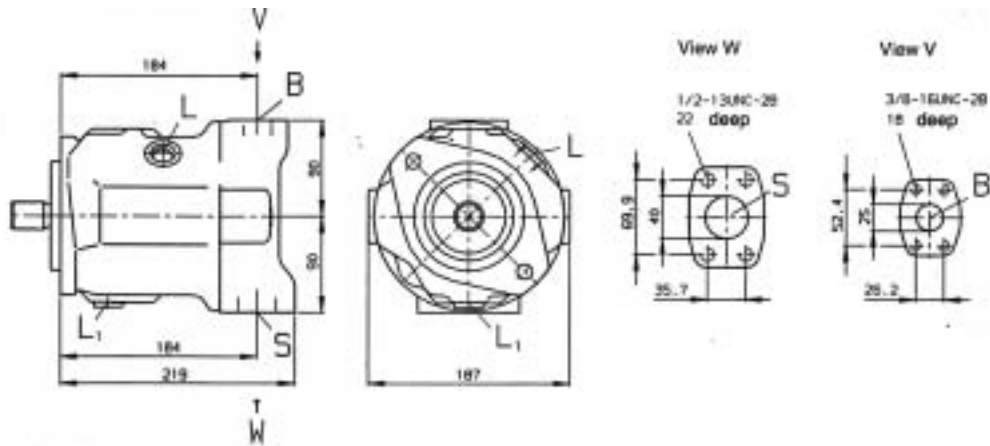

Rear Ports, without PTO,

L: case drain port M22x1,5

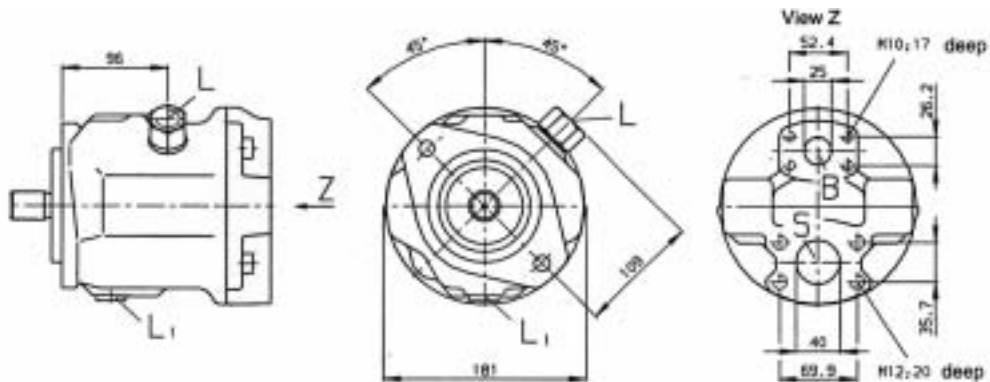

Side Ports, without PTO

L: case drain port M22x1,5

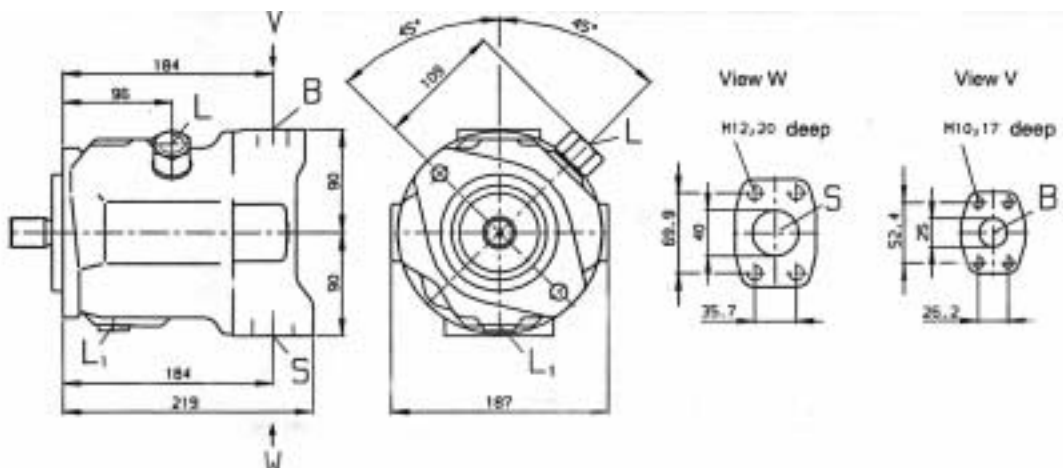

7. MAIN DIMENSIONS, Size 71

Rear Ports, without PTO,
without control

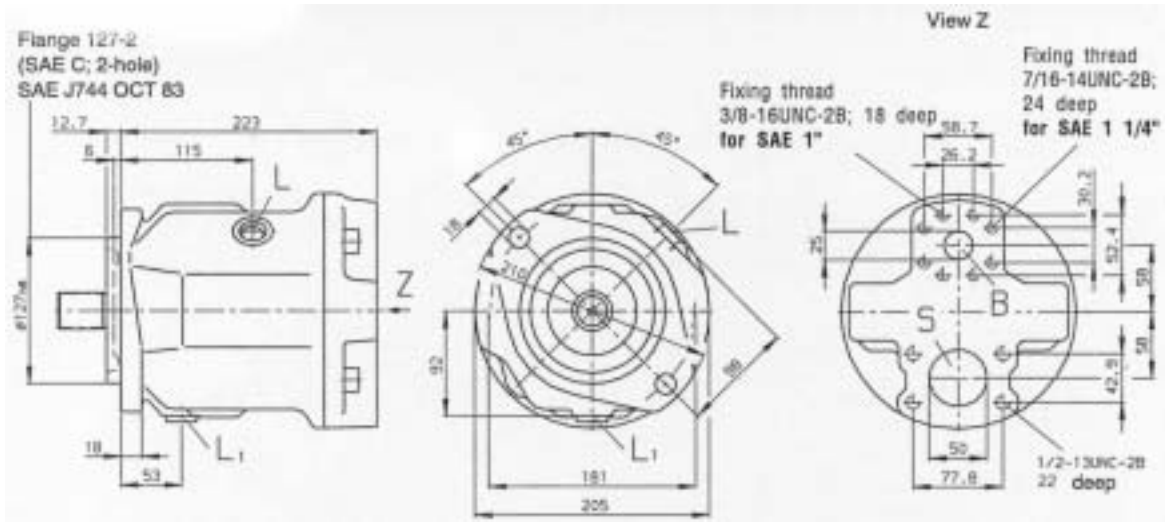

Shaft S

Shaft 32-4; (SAE C)
SAE J744 OCT 83

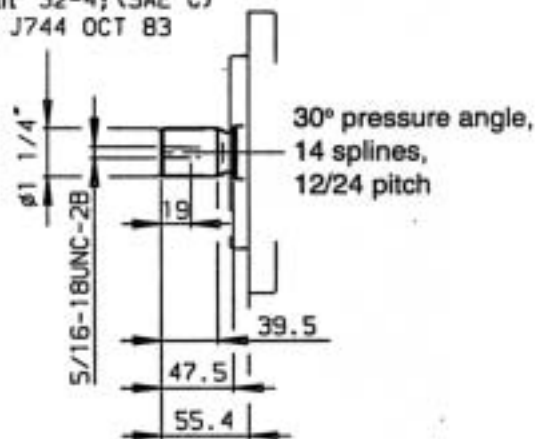

Ports

B	Pressure port	SAE 1"	(standard pressure series)
S	Suction port	SAE 2"	(standard pressure series)
L	case drain port	7/8-14 UNF-2B	
L1	case drain port	7/8-14 UNF-2B	(sealed in factory)

MAIN DIMENSIONS, Size 71

Side Ports, without PTO

L: case drain port 7/8-14 UNF-2B

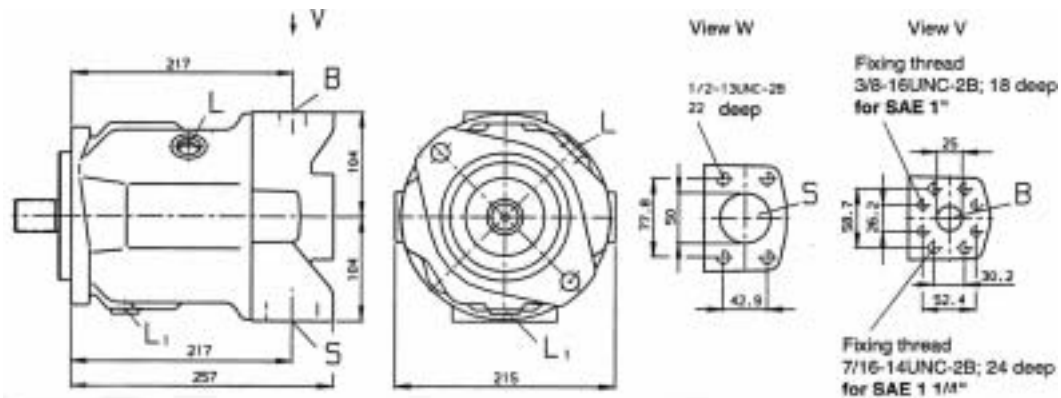

Rear Ports, without PTO

L: case drain port M22x1,5

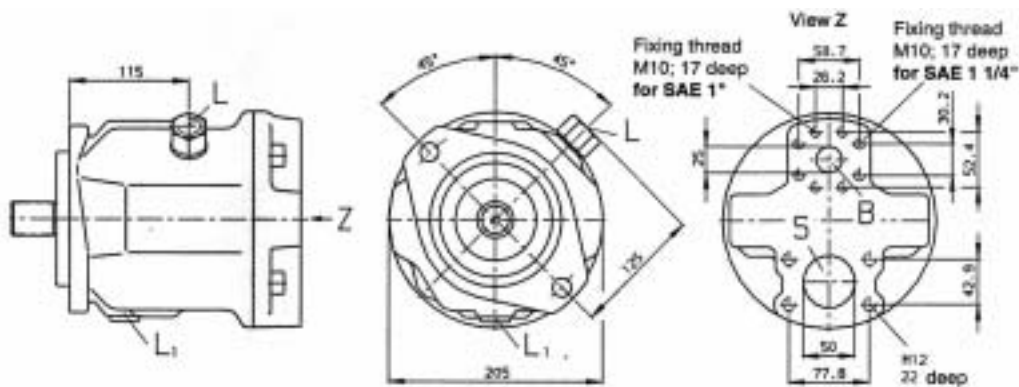

Side Ports, without PTO

L: case drain port M22x1,5

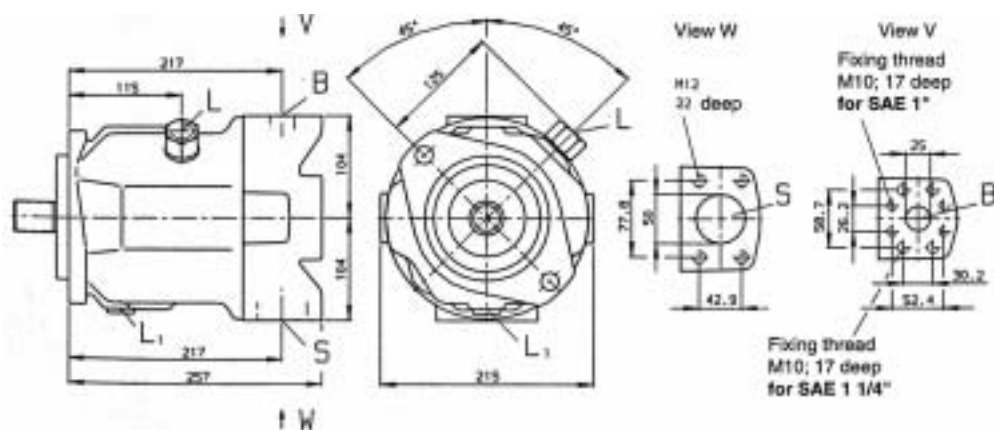

8. DIMENSIONS for LS DA-CONTROL

Dimensions LS DA-control Rear Ports

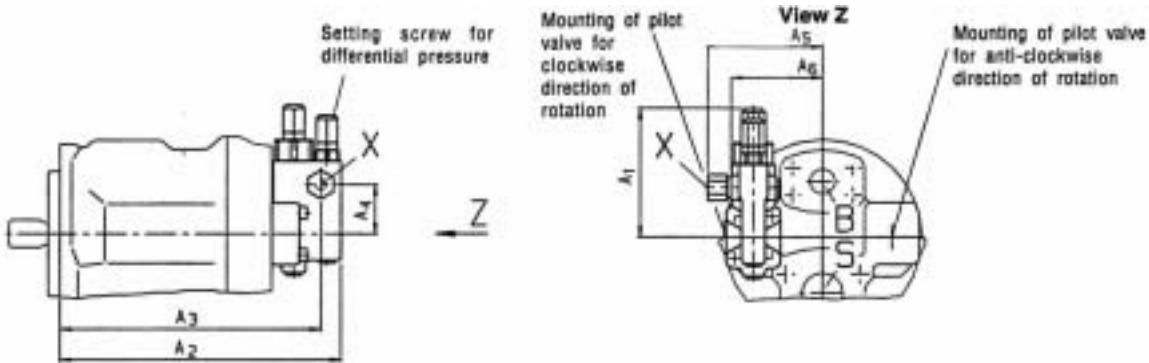

Dimensions LS DA-control Side Ports

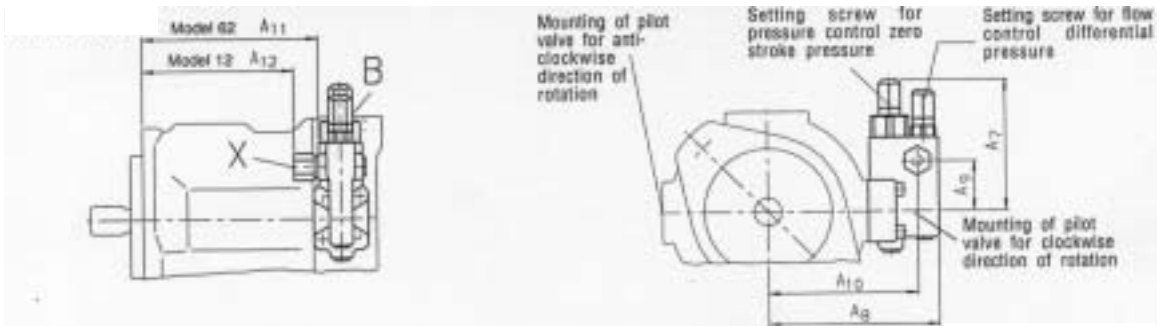

Size	A ₁	A ₂	A ₃	A ₄	A ₅ metr.	A ₆ UNF	A ₇	A ₈	A ₉	A ₁₀	A ₁₁ UNF	A ₁₂ metr	Port X UNF	Port X metr.
28	109	225	209	43	94	73	106	136	40	119	140	119	7/16-20 UNF-2B; 10 deep	M14x1,5; 12 deep
45	106	244	228	40	102,5	81,5	106	146	40	129	155	134	7/16-20 UNF-2B; 10 deep	M14x1,5; 12 deep
71	106	278	262	40	112,5	91,5	106	160	40	143	183	162	7/16-20 UNF-2B; 10 deep	M14x1,5; 12 deep

9. MAIN DIMENSIONS of TANDEM PUMPS

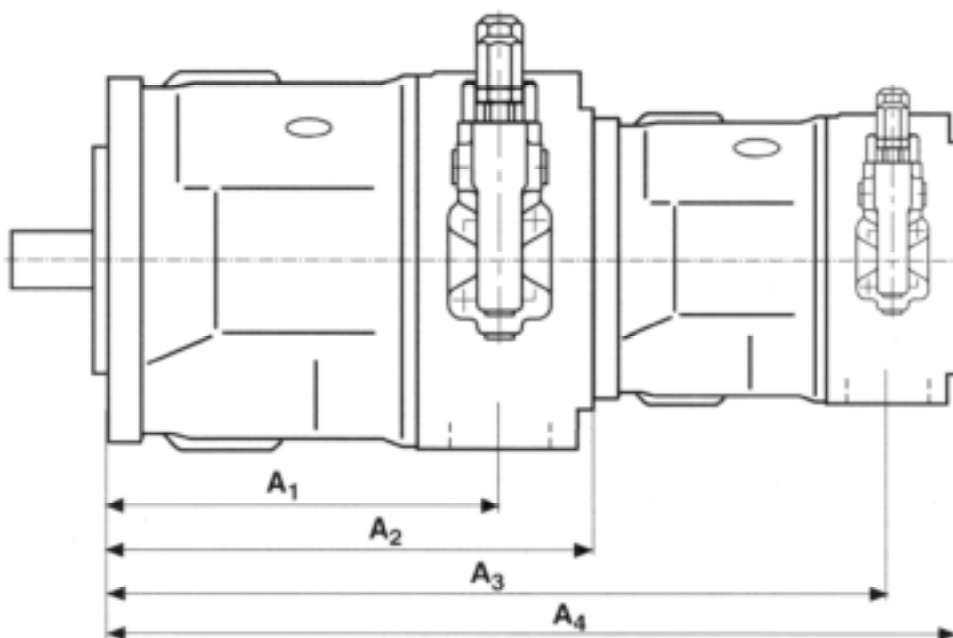

pump 1 \ pump 2	MPR 28-01				MPR 45-01				MPR-71-01			
	A1	A2	A3	A4	A1	A2	A3	A4	A1	A2	A3	A4
MPR 28-01	165	204	369	398	184	229	394	423	217	267	432	461
MPR 45-01					184	229	413	448	217	267	451	486

10. DIMENSIONS of PTO's

SAE A (2-hole)

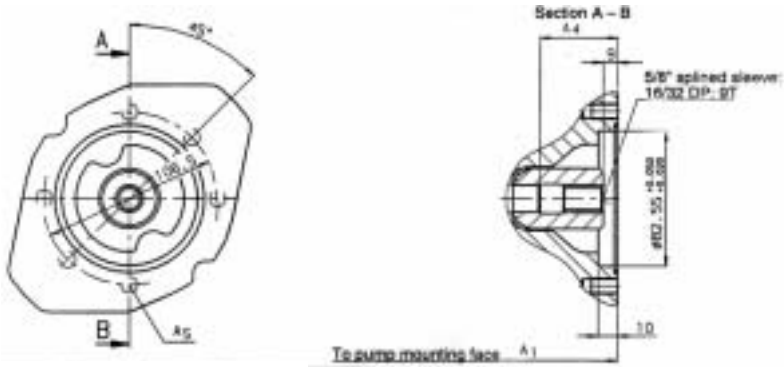

Size	A1	A4	A5
28	204	47	M 10; 16 deep
45	229	53	M 10; 16 deep
71	267	61	M 10; 20 deep

SAE B (2-hole)

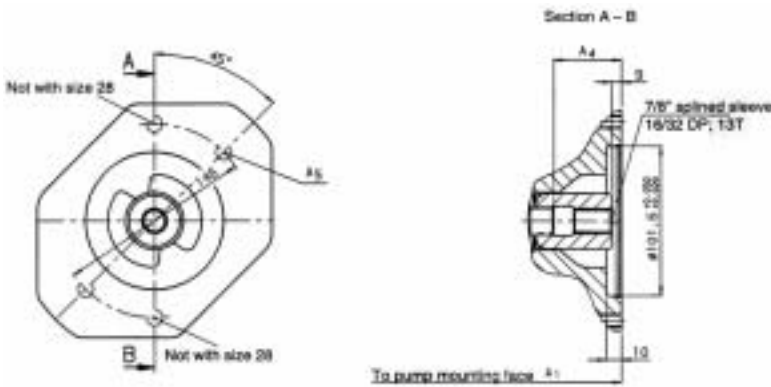

Size	A1	A4	A5
28	204	47	M 12; 15 deep
45	229	53	M 12; 18 deep
71	267	61	M 12; 20 deep

SAE B-B (2-hole)

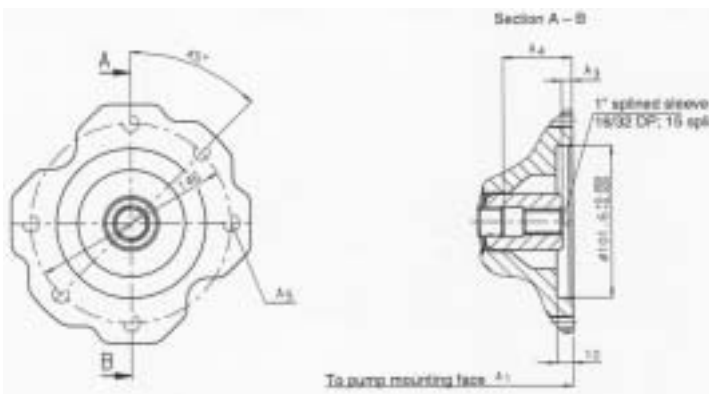

Size	A1	A3	A4	A5
45	229	9	53	M 12; 18 deep
71	267	8	61	M 12; 20 deep

11. PRODUCT PHOTOS MPR-01 (Selection)

**MPR 71-01
with axial ports**



**Tandem Pump
MPR 45-01 + MPR 45-01
with side and axial ports**

C. PRESSURE FLUIDS AND FILTRATION

Permitted Pressure Fluids

- Mineral oil HLP to DIN 51 524.
- biodegradable fluids upon request
- Other pressure fluids upon request

Technical Data

Pressure Fluid Temperature Range	[°C]	-20 bis +90
Working Viscosity Range	[mm ² /s] = [cSt]	10 bis 80
Optimum Working Viscosity	[mm ² /s] = [cSt]	15 bis 30
Max. Viscosity (short time start up)	[mm ² /s] = [cSt]	1000

Viscosity recommendations

Working temperature [°C]	Viscosity class [mm²/s] = [cSt] at 40°
bis 40	22
ca. 60 bis 80	46 oder 68

Linde recommend using only pressure fluids which are confirmed by the producer as suitable for use in high pressure hydraulic installations. For the correct choice of suitable pressure fluid it is necessary to know the working temperature in the hydraulic circuit (closed loop). the pressure fluid chosen must allow the working viscosity to be within the optimum viscosity range (refer to above table).

Attention!

Due to pressure and speed influences the leakage fluid temperature is always higher than the circuit temperature . The temperature must not exceed 90°C in any part of the system. Under special circumstances, if the stated conditions cannot be observed then please consult Linde.

Filtration

In order to guarantee proper functions and efficiency of the hydraulic pumps the purity of the pressure fluid over the entire operating period, must comply to at least class 18/13 according to ISO 4406.

With modern filtration technology, however, much better values can be achieved which contributes significantly to extending the life and durability of the hydraulic pumps and complete system.

D. APPLICATIONS



E. LINDE DIRECT

Linde Hydraulics Direct Lines

You can contact us

- **By Telephone** +49-60 21-99-0 (switchboard)
- **By Fax** +49-60 21-99-42 02
+49-60 21-99-42 30
- **By email** info.hydraulics@linde-mh.de
- **By internet** www.linde-hydraulics.com
- **By Post** Linde AG
Linde Material Handling Division

Grossostheimer Strasse 198
D-63741 Aschaffenburg

PO Box 100136
D-63701 Aschaffenburg

Linde AG
Linde Material Handling Division
Schweinheimer Str. 34 · D-63743 Aschaffenburg